

Single & TwinCut

Roll surface cleaning

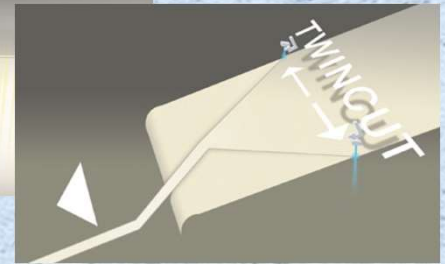
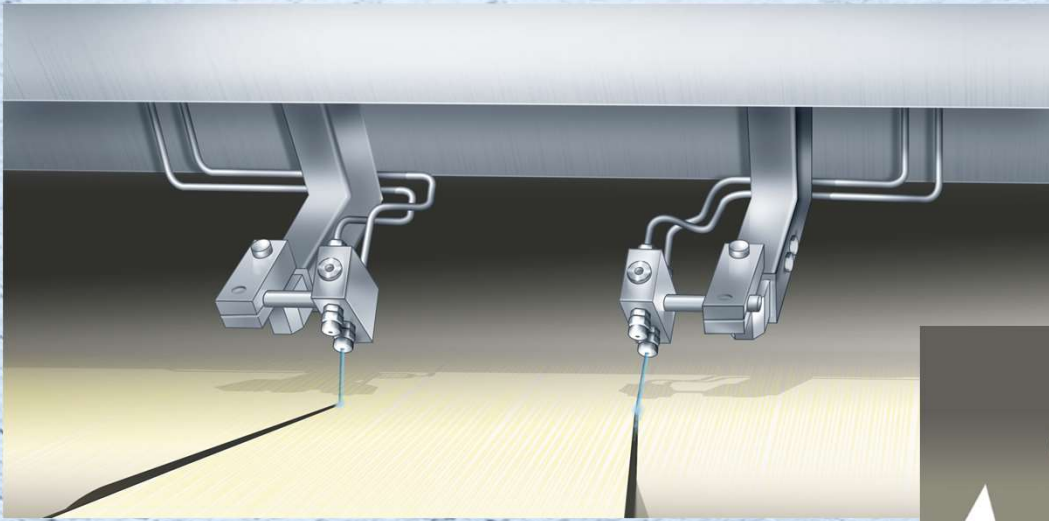

Fastpap tail cutters TwinCut and SingleCut allow for quick and successful tail threading. Their top-class reliability and highly repeatable accuracy help you achieve more production time.

Outstanding dependability

Tail threading is a critical operation, whose success depends remarkably on the faultless performance of the tail cutter. In developing Fastpap tail cutters, we have concentrated particularly on the reliability and durability of the equipment. The requirements imposed by difficult conditions have been considered both in the design of the cutter's structure and in its component choices.

SingleCut and TwinCut tail cutters are based on uncomplicated, proven technology. Thanks to the reserve nozzles and the possibility of manual operation, you can rely on the tail cutters operating even in case of malfunction.

TwinCut – double tail cutter

Fastpap TwinCut is especially suitable for threading on online coating machines, where controlling the tail end after cutting can be difficult. TwinCut cuts the tail at the web edge with two cutting heads and, after threading, moves it to the center of the machine and finally widens it to the edges. If needed, either one of the cutting heads can also be used solely for widening the web to the full width.

BENEFITS

- Steady, adjustable movement of the cutting jet
- No dust, no sharpening
- Programmable tail widths
- Reduction in threading time
- Manual operation possible
- Reliability in extreme conditions
- Easy installation and service

Fastpap

Single & TwinCut

Roll surface cleaning

Advanced features

According to customer needs, several tail widths can be programmed for SingleCut and TwinCut, and they are easily adjustable. The cutting takes place either in the open draw or against a cylinder. The movement of the cutting jet is steady, and the repeatability of positioning is excellent.

The speed of the cutting head is adjustable over a large scale, and its acceleration and deceleration can be programmed. If needed, you can manually trim the tail width at slow speed or at normal widening speed.

Easy to install and maintain

The compact structure of Fastpap tail cutters makes them easy to install even in tight spaces. The cutting heads can be driven outside the hood, where it is possible to carry out maintenance activities, such as changing the nozzles, while production is continuing.

Technical data

Beam:

SingleCut height / width: 430 / 280 mm
SingleCut weight: 300 - 1250 kg
TwinCut height / width: 440 / 365 mm
TwinCut weight: 435 - 1 813 kg
Length: 3 000 - 12 500 mm
Material: AISI 304 (AISI 316 optional)
Maximum operating temperature: 120° C

Nozzle head:

Traversing area (CD): 2 000 - 11 500 mm
Traversing speed: 50 - 1 500 mm/s
Repeatability of tail width: better than ± 2 mm / nozzle head
Maximum cutting pressure: 1 000 bar
Material: AISI 304 (AISI 316 optional)
Pre-programmable tail widths
Option for SingleCut: blade cutting instead of a water jet

Pneumatic and water systems:

Air supply pressure: 4 - 7 bar (tail stabilisation option)
Water supply pressure: 3 - 10 bar
Double pump station included (500bar / 1000 bar)

Electricity system:

3 x 400VAC (50Hz)

Control system

Siemens S7

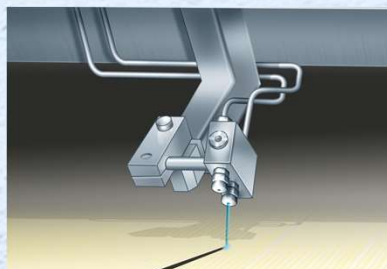

Absolute accuracy.

Fastpap Oy
Vesimyllynkatu 3
FI-33310 Tampere, Finland
Tel. +358 3 3142 4400
info@fastpap.com
www.fastpap.com

Fastpap